

Advanced Certificate in Mechanical Engineering

Introduction

The Advanced Certificate in Mechanical Engineering is a two-year (2400hours) training programme offered full-time to secondary five (S5) school leavers and learners from School of Advanced Level (SALs) as well as from other professional centres. This is equivalent to four (4) semesters. Two semesters represents one academic year. A learner on full time may exit after year one and qualify for the Certificate after successfully completing all the units from semesters one and two and accumulated 120 credits.

Entry Criteria

Learners wishing to apply for the Advanced Certificate in Mechanical Engineering must have attained a grade of “E” from the **IGCSE examinations** in English, Mathematics and Physics or Design Technology.

Applicants from another professional centre may be accepted exiting with a Certificate from that Institution.

Learners should be able to:

- ⇒ Demonstrate an in-depth knowledge of the manufacturing, commissioning and maintenance procedures used in the trade of mechanical engineering.
- ⇒ Demonstrate comprehensive range of specialized manufacturing and maintenance skills using all commonly used mechanical hand and power tools in compliance with all relevant health and safety legislation and best practice.

Advanced Certificate in Mechanical Engineering

Career Opportunities in the Mechanical Engineering

Career Opportunities in the Mechanical Engineering Industry exists. A graduate mechanical engineer will work with new technologies, for example advanced materials, new manufacturing processes or highly efficient cooling systems, converting demanding requirements into optimized production component designs. Later in their careers they might be leading the innovation of these technologies, for example the composite fan. Alternatively, they may be leading engineering teams that apply those technologies to the next generation of power systems.

Most of the graduate roles in the fast-moving consumer goods industry are in one of two areas: manufacturing/engineering or supply network operations/logistics. For both of these areas, the work is not defined in nice separate buckets of mechanical, electrical, chemical etc., but is normally a mixture of different engineering disciplines as a general manufacturing or logistics engineer. Graduates will pick up skills from other disciplines as they go through their training and career.

A mechanical engineer in the materials and metals industry will be involved in the design, development and testing of a range of complex mechanical systems. They will work on the full maintenance lifecycle of the mechanical plant items (steam turbines, gas turbines, pumps, valves, pipework, coal mills, fans etc.)

Progression and Further Studies

Graduates on the Advanced Certificate in Mechanical Engineering can apply for the National Diploma in Mechanical Engineering.

Graduates with a National Diploma in Mechanical Engineering can be accepted in different universities for a degree study in Mechanical Engineering with specialization such as Mechanical Engineering,

Advanced Certificate in Mechanical Engineering

Assessment Technique (s) including weighting (s)

The Advanced Craft Certificate grade is based on a weighted average of all unit result grades. Assessment approach varies from one unit to another. During every unit of study there is a minimum number of continuous assessments which the learner must undertake. This could be in the form of small tests and assignments and research. For the final unit assessments, in most cases a learner will have to sit for both a theory paper which can be multiple choice, structured or a mixture and a practical for skills demonstration.

Work based experience (WBE) is a compulsory unit and is assessed by the supervisor in the work place for full-time learners and through compilation of a portfolio and assessed against the performance criteria for the different elements in the WBE unit for learner on part-time.

To attain the required standard, a minimum of a pass grade must be achieved in all assessments prescribed .

Pass mark for every unit on the programme is **55%**.

As per SIT Assessment Policy, the final mark for a unit is made up of 40% of all continuous assessments plus 60% from the results of the final unit assessment (s) and the following grades and corresponding marks are used

Not yet Competent- NYC-0	-	54%
Pass	- P	55%-69%
Credit or Merit	- M or C	70% - 84%
Distinction	- D	85%+

Advanced Certificate in Mechanical Engineering

- ⇒ Exercise appropriate judgment in planning, diagnostics and delivering all services, installations and maintenance processes relating to the mechanical equipment, mechanical plants, arc and gas welding.
- ⇒ Transfer and apply theoretical understanding and technical know-how to inspect, diagnose faults, maintain and repair mechanical systems in a wide variety of domestic and commercial contexts.
- ⇒ Exercise substantial independence in the workplace, taking responsibility for mechanical and manufacturing duties performed by others and interacting with a variety of individuals and groups to include customers, colleagues and suppliers.
- ⇒ Take initiative to identify and address self-development and training needs in both an employment and structured training environment.
- ⇒ Determine the function and role of a mechanical engineer in society to include an awareness of energy conservation and other relevant ecological concerns.

Certification

To be awarded the Advanced Certificate in Mechanical Engineering, the learner must have achieved the expected performance criteria set out in the different elements of each unit that make up the programme. The total credit requirement for this Advanced Certificate is 240 Credits . This qualification is at level 4 on the National Qualification Framework (NQF).

Advanced Certificate in Mechanical Engineering

List of Statements of Competencies

Statement of Competencies	Unit title	Semester (s) involved	Credits
Apply health, safety and security procedures in the context of mechanical engineering	Health, Safety and Security Procedures	1	4.5
Maintain mechanical engineering tools and instruments	Engineering Tools & Instruments	1	4.5
Demonstrate knowledge of the occupation of a mechanical engineer in the context of Seychelles	Mechanical Engineering Occupation	1	3
Demonstrate knowledge of engineering materials and their properties	Engineering Materials	1	4.5
Apply knowledge of electromagnetism	Electromagnetism	2	4.5
Apply principles and practices of electrical and electronics applications	Electrical and Electronics applications	3	6.0
Use oral and written English in the context of mechanical engineering	Technical English	1	3
Apply mathematical principles	Mathematics	1 & 3	7.5
Apply engineering scientific principles	Basic Engineering Science	1 & 3	7.5

Advanced Certificate in Mechanical Engineering

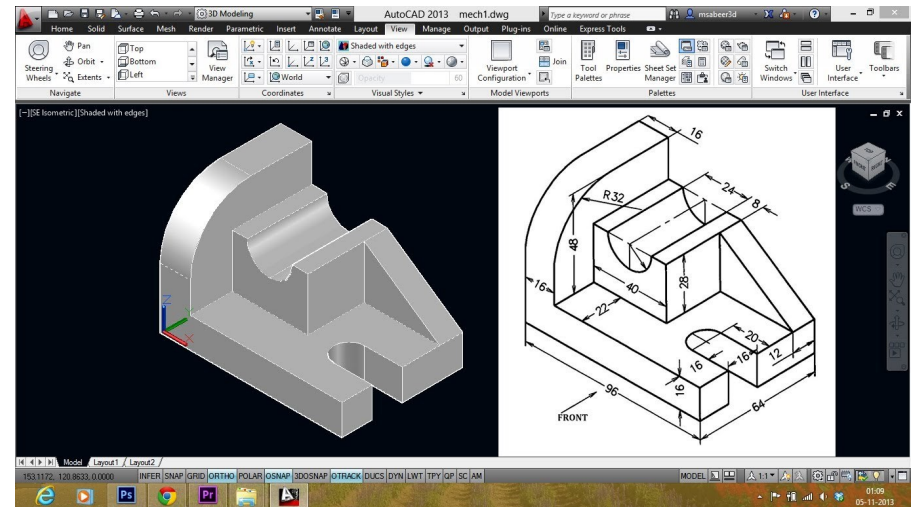
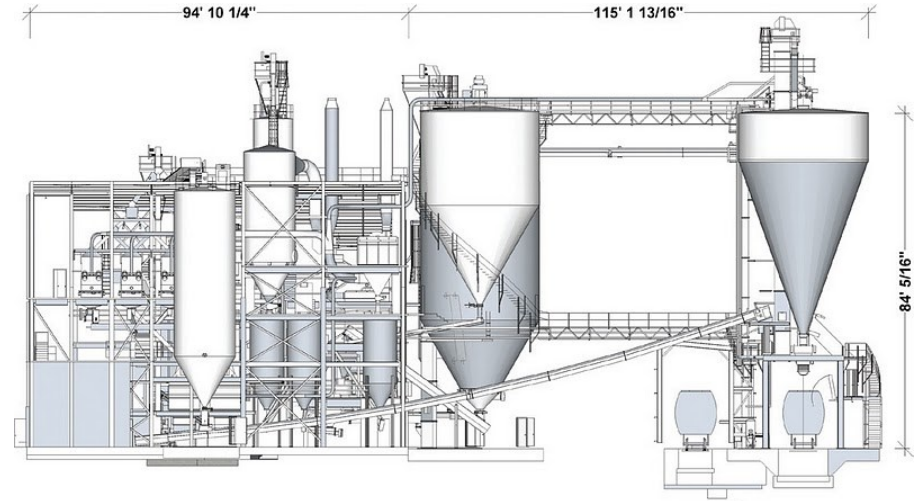

Advanced Certificate In Mechanical Engineering

Structure of the Programme :

Semester 1	Semester 2	Semester 3	Semester 4
Health, Safety and Security Procedures (30/15)			
Engineering Materials (30/15)		Mechatronics (30/15)	
Engineering Tools & Instruments (30/15)	Sheet Metal work 1 (50/25)	Sheet Metal work 2 (40/20)	Entrepreneurship (20/10)
Basic Arc Welding (60/30)		Advanced Arc Welding 1 (40/20)	Advanced Arc Welding 2 (60/30)
Occupation in the context of Seychelles (20/10)	Basic Gas Welding (60/30)	Advanced Gas Welding 1 (40/20)	Advanced Gas Welding 2 (40/40)
	Electromagnetism (30/15)	Electrical & Electronics Applications (40/20)	Plant Maintenance (20/10)
Basic Engineering Science 1 (30/15)	Machining & Fittings 1 (60/60)		Machining & Fittings 2 (40/20)
Mathematics 1 (20/10)		Mathematics 2 (30/15)	
Technical English (20/10)	ICT (20/10)	Basic Engineering Science 2 (20/10)	
Basic Technical Drawing Techniques 1 (20/10)	Basic Technical Drawing Techniques 2 (20/10)	Basic Auto Cad 1 (20/10)	Basic Auto Cad 2 (20/10)
Work Based Experience (W.B.E rotation 1) (210)	Work Based Experience (W.B.E rotation 2) (210)	Work Based Experience (W.B.E rotation 3) (210)	Work Based Experience (W.B.E rotation 4) (280)
Number of contact hours / Non-contact hours per semester			
Semester one: 260/130 (390) Notional Hours (260+30+210) = 600	Semester two: 240/150 (390) Notional Hours (240+170+210) = 600	Semester three: 260/130 (390) Notional Hours (260+130+210) = 600	Semester four: 200/120 (320) Notional Hours (200+120+280) = 600
Total hours for the two year program: 2400			

Advanced Certificate in Mechanical Engineering

Demonstrate knowledge of basic arc welding	Basic Arc Welding	1 & 2	9
Apply knowledge and skills of advanced arc welding	Advanced arc welding	3 & 4	15
Demonstrate understanding of basic gas welding	Basic Gas Welding	2	9
Apply knowledge and techniques of advanced gas Welding	Advanced Gas Welding	3 & 4	15
Use information and communication technology (ICT) skills	ICT	2	3
Apply techniques of machining and fittings	Machining and fittings	2 & 4	18
Apply techniques of plant maintenance	Plant maintenance	4	3
Apply principles and practices of sheet metal work	Sheet Metal Work	2 & 3	12.5
Apply principles and practices of basic technical drawing	Basic Technical Drawing Techniques	1 & 2	6
Produce drawings using Auto CAD	Basic Auto CAD	3 & 4	6
Demonstrate knowledge of Mechatronics and its applications.	Mechatronics	3	4.5
Demonstrate understanding of Entrepreneurship	Entrepreneurship	4	3
Apply knowledge and skills of mechanical engineering during work based experience (WBE)	WBE	1,2,3,4	91
Total number of credits			240

Advanced Certificate in Mechanical Engineering

Training Resources Required for Study

- Learners are expected to have drawing equipment such as ruler, Tri Square, T-Square, protractors.
- Overall and safety shoes are mandatory in the Mechanical workshop.

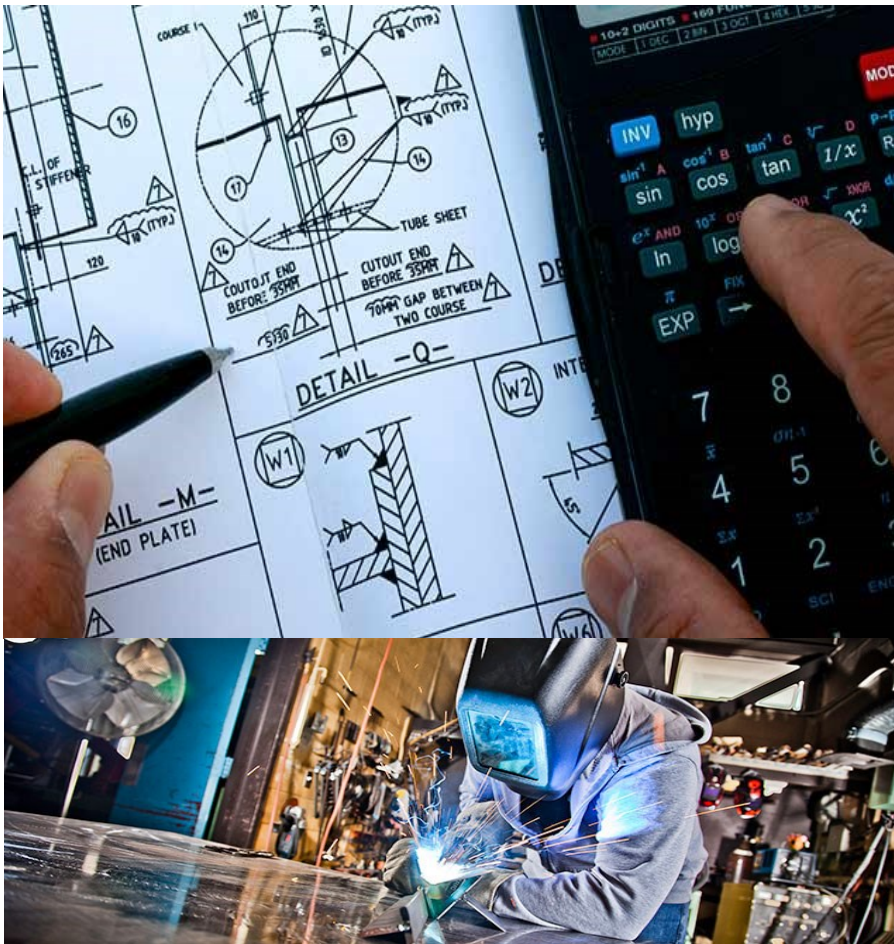

6

Advanced Certificate in Mechanical Engineering

Books and References for Study

A number of publications are available for study and training in the Advanced Certificate in Mechanical Engineering. They are books which are regularly updated with new editions. Learners are advised to identify the latest versions.

The following are available in the SIT Library and can be borrowed for study and references:

- An Introduction to technical Drawing, A. Yarwood
- Technical Drawing for G.C.E and C.S.E, J.N Green
- Mathematics for technicians New level 1 A.Greer and G.W.Taylor
- Maintenance Engineering Handbook by Lindley Higgins and Keith Mobley
- Plant Equipment & Maintenance, Engineering Hand book by Duncan C. Richardson
- GCSE Additional Applied Science Student Book by Nuffield/ York.
- Physical Metallurgy: Principle and Practice, V. Raghavan. Prentice Hall India Pvt Ltd.
- Machine Tool Technology by K S Yadav
- Industrial Safety & environment, Anupana Prashav
- Engineering Fundamentals, Roger Timings
- Mechanical Workshop Practice by K. C. JOHN
- Sheet Metal Work (Workshop Practice) by R.E. Wakeford
- Basic Welding and Fabrication W Kenyon

The following websites contain journals and articles on mechanical engineering:

- <http://www.academicjournals.org/journal/JMER>
- <http://www.ccsenet.org/journal/index.php/mer>
- <http://journals.sagepub.com/home/ade>